

Kleinleistungstransistoren für HF-/ZF-/Video-Anwendungen

Typ	Struktur	Grenzwerte ($T_a = 25^\circ\text{C}$)				Kennwerte											Bauform	
		P_{tot} (mW)	U_{CBO} (V)	U_{CEO} (V)	I_{C} (mA)	$h_{21\text{E}}$ bei I_{C}	U_{CE} (V)	f_{T} bei I_{C} (MHz)	U_{CEsat} bei I_{C} (mV)	F bei U_{CE} ; I_{C} (dB)	f (MHz)	C_{cre}^* (pF)						
SF 116*	pnp	0,6	-20	-20	-500	28...560	-50	-2	≥ 60	-10	$\leq -0,5$	-150						80
SF 117*	pnp	0,6	-30	-30	-500	28...560	-50	-2	≥ 60	-10	$\leq -0,5$	-150						80
SF 118*	pnp	0,6	-60	-60	-500	28...560	-50	-2	≥ 60	-10	$\leq -0,5$	-150						80
SF 119*	pnp	0,6	-80	-80	-500	28...280	-50	-2	≥ 60	-10	$\leq -0,5$	-150						80
SF 126*	nnp	0,6	33	20	500	18...1120	50	2	≥ 60	10	$\leq 0,5$	150						80
SF 127*	nnp	0,6	66	30	500	18...1120	50	2	≥ 60	10	$\leq 0,5$	150						80
SF 128*	nnp	0,6	100	60	500	18...1120	50	2	≥ 60	10	$\leq 0,5$	150						80
SF 129*	nnp	0,6	120	80	500	18...1120	50	2	≥ 60	10	$\leq 0,5$	150						80
SF 136*	nnp	0,3	20	12	200	18...1120	10	1	≥ 300	10	$\leq 0,3$	10	7,3	6	0,2	100		76
SF 137*	nnp	0,3	40	20	200	18...1120	10	1	≥ 300	10	$\leq 0,3$	10	7,5	6	0,2	100		76
SF 225	nnp	0,20	40	25	25	> 40	1	10	500	1			5	10	1	0,2	0,6	81
SF 235	nnp	0,20	40	25	25	> 28	1	10	740 ²⁾	1			4	10	1	100	0,35	81
SF 245	nnp	0,20	40	25	25	> 37	7	10	960	7			2,9	10	2	200	0,45	81
SFE 225	nnp	0,15	40	25	25	> 40	1	10	390	1			5	10	1	0,2	0,6	78
SFE 235	nnp	0,15	40	25	25	> 28	1	10	750 ²⁾	1			4	10	1	100	0,35	78
SFE 245	nnp	0,15	40	25	25	> 37	7	10	910	7			2,9	10	2	200	0,5	78
SF 357	nnp	6	160	160	100	> 25	30	10	60	15	1	30						82
SF 358	nnp	6	250	250	100	> 25	30	10	60	15	1	30						82
SF 359	nnp	6	300	300	100	> 25	30	10	60	15	1	30						82
SF 369	nnp	2	250	250	30	> 50	30	10	60	10	1	30						82

* selektiert nach der Stromverstärkung 2) f_{yfb}



Bild 76



Bild 81

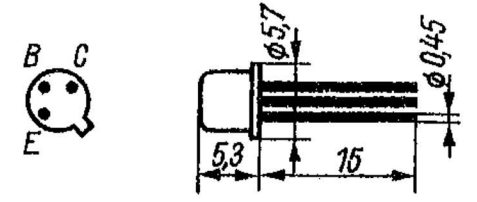

Bild 80

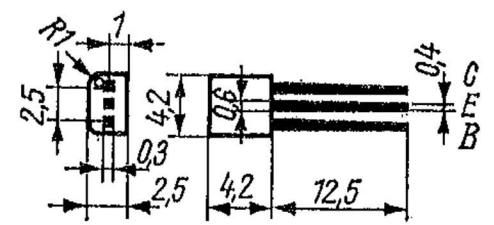

Bild 78

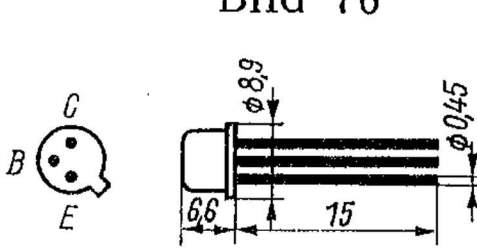
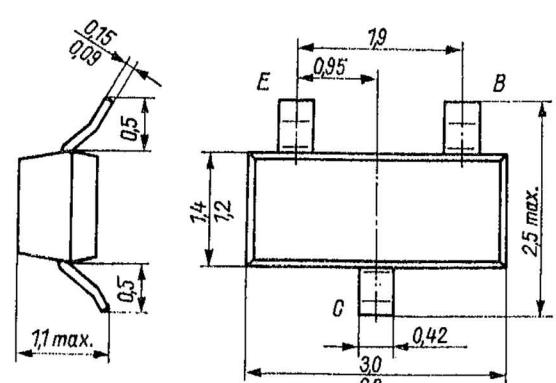
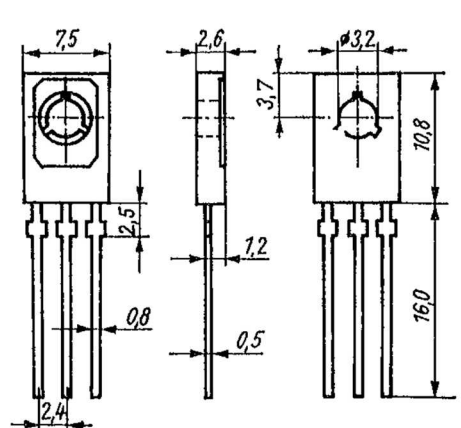

Bild 82